



**BAHRAIN ROYAL EQUESTRIAN
& ENDURANCE FEDERATION**

NATIONAL DRESSAGE COMPETITIONS RULES

These Rules are effective from 01 October 2023
and
replace all previously issued Rules, Regulations and Instructions.

Contents

MISSION STATEMENT.....	6
SECTION 1 - INTRODUCTION AND DEFINITIONS	6
Article 100: General Regulations.	6
Article 101: Rules.	7
Article 102: Application of Rules.	7
Article 103: Financial Responsibility.	7
Article 104: Definitions.	7
SECTION II - GENERAL RULES.....	9
CHAPTER I: CODE OF CONDUCT	9
Article 105. Code of Conduct for the Welfare of the Horse:.....	9
Article 106. Code of Conduct for Good Sportsmanship:	9
CHAPTER II: DRESSAGE.....	10
Article 107. Object and General Principles of Dressage.....	10
CHAPTER III: COMPETITIONS	11
Article 108. Recognition.	11
Article 109. Competition.....	11
109.1 Competition Levels.	12
Article 110: Levels of Competitions.	14
Article 111: Tests.....	14
Article 112: Execution of the Test.	14
Article 113: Time and Technical Failure.	19
Article 114: Judges' Sheets.....	20
Article 115: Results and Calculation of Scores.	21
Article 116: Entries.	22
Article 117: Schedules.	22
Article 118: Organisers.....	23
Article 119: Arena and Exercise Arenas (For Diagram see annex arena).....	23
Article 120: Medical and Veterinary Services.	24
Article 121: Starting Possibilities.	25
Article 122: Identification.	25
Article 123: Hors Concours (HC).....	25
Article 124: Callers.....	26
Article 125: Warming-Up.	26

Article 126: Unforeseen Circumstances.....	27
CHAPTER IV: THE BAHRAIN ROYAL EQUESTRIAN & ENDURANCE FEDERATION CHAMPIONSHIPS.....	27
Article 127: Place and Date.	27
Article 128: Entry Qualification.....	27
Article 129: Competitions in the National Championships.....	28
CHAPTER V: FEI WORLD DRESSAGE CHALLENGE SELECTION/QUALIFYING RULES.....	28
CHAPTER VI: CEREMONIES, PRIZES AND EXPENSES	29
Article 130: Ceremonies.....	29
Article 131: Prizes.	29
Article 132: Expenses.....	29
CHAPTER VII RIDERS	30
Article 133: General.....	30
Article 134: Registration – Riders.....	30
Article 135: Person Responsible.....	30
CHAPTER VIII: HORSES.....	31
Article 136: Eligibility.	31
Article 137: Registration – Horses.....	31
Article 138: Horses Name.....	31
Article 139: Horses – Age.....	32
Article 140: Competitive Conditions.	32
CHAPTER IXI: DRESS	32
Article 141: Article Dress Code – General.....	32
Article 142: Advertising.....	32
Article 143: Jacket/Coat.....	33
Article 144: Hats.	33
Article 145: Breeches/Jodhpurs.....	33
Article 146: Gloves.....	34
Article 147: Boots.....	34
Article 148: Spurs.....	34
Article 149: Whips.....	34
Article 150: Earphones.	35
CHAPTER X: SADDLERY.....	35
Article 151: Saddles.....	35

Article 152: Saddle Clothes.....	36
Article 153: Logos.....	36
Article 154: Bridles and Bits.	36
Article 155: Gadgets.....	36
Article 156: Decorations.....	37
Article 157: False Tail/Tail Extensions.	37
Article 158: Ear Hoods.....	37
Article 159: Checking of Saddlery.	38
Article 160: Saddlery and bits in the warming-up and training arenas.....	38
CHAPTER XI: GRADING SYSTEM.....	38
Article 161: Grading Average:.....	38
Article 162: Grading/Upgrading Horse rider combinations.	38
Article 163: Downgrading of Horse and rider combinations.	39
Article 164: Grading of Riders.....	39
CHAPTER XII: SAFETY.....	39
Article 165: Horse out of control.....	39
Article 166: Disobedience.....	40
Article 167: Dangerous situations.....	40
CHAPTER XIII: PROTECTION OF ATHLETES AND HORSES.....	40
Article 168: Protection of Athletes.....	40
Article 169: Protection of Horses.....	41
Article 170: Abuse of Horses.....	41
Article 171: Medication Control and Anti-Doping.....	41
Article 172: Veterinary Examination.....	42
CHAPTER XIV: JUDGES AND OFFICIALS.....	42
Article 173: Mission.....	42
Article 174: Conflict of Interest.....	43
Article 175: Reports.....	43
Article 176: Federation Officials Code of Conduct A.....	43
Article 177: Federation Officials Code of Conduct B.....	43
Article 178: Judges.....	44
Article 179: Official Representative at an Event.....	44
Article 180: Senior Judge/Ground Jury – Duties.....	44
Article 181: Stewards.....	46
CHAPTER XV: THE LEGAL SYSTEM.....	47

Article 182: Preamble.....	47
Article 183: Federation Powers.....	47
Article 184: Penalties and Warnings.....	47
CHAPTER XVI: OBJECTIONS	50
Article 185: Submission of Objections.	50
Article 186: Time Limit.	50
Article 187: Referral to Federation.....	51
Article 188: Query.	51
Article 189: Appeal.....	51
Appendix 1: Permitted Bridles/Bits.	52
Appendix 2: Arenas.....	55

MISSION STATEMENT

The Mission of The Bahrain Royal Equestrian & Endurance Federation with this Rule Book is to Promote, Guide, Develop and Manage Dressage in The Kingdom of Bahrain and to do so in a manner which promotes the highest standards in both Equestrianism and Animal Welfare.

SECTION 1 - INTRODUCTION AND DEFINITIONS

Article 100: General Regulations.

1. These Rules are established so that competitors and teams of competitors may compete against each other under fair and equal conditions.
2. They can, however, never cover every eventuality. Matters, which cannot be resolved by interpreting the rules to the letter, shall be resolved in the spirit of the Rules to obtain a solution, which fairly represents the ethics, integrity and spirit of the sport.
3. Recourse to FEI Rules is permitted when appropriate and not covered by NF Rules and authorized by NF.
4. It is the absolute, sole and personal responsibility of all Officials and persons registered with the Federation to be fully familiar with all published Rules, Regulations and Instructions of the Federation, as ignorance of any such Rules, Regulations or Instructions will never be accepted as a valid excuse for, nor as mitigation for, transgressions which may occur.
5. The NF will publish rules online as well as periodic updates.
6. It is the sole responsibility of the rider to ensure that they are and up to date regarding the rules.
7. For further clarification on rules and regulations related to dressage email info@breefdressage.com

Article 101: Rules.

These Rules have been drawn up in the broadest possible spirit to allow Organisers of events as much freedom as possible in the preparation and management of their programs.

Article 102: Application of Rules.

1. The Dressage Rules of The Bahrain Royal Equestrian & Endurance Federation (NF) shall apply to all events held under the auspices of NF, rather than International Events, which must be held under the Rules of the Federation Equestre International (FEI).
2. Local amendments to dressage rules to be reviewed by the Dressage Committee prior to implementation.

Article 103: Financial Responsibility.

The BREEF accepts no financial responsibility whatsoever for events held under its auspices or under its rules.

Article 104: Definitions.

Terms used in these Rules are defined as follows:

Agent: An employee of, or other person, who is duly authorized by, an Owner or person registered with NF.

Competition: The term "competition" refers to each individual class for which placings and prizes are awarded.

Discipline: The term "discipline" refers to the type of event or competition which can be either, Dressage, Show Jumping, Eventing, Combined Event, or any other which the Federation may decide.

Event: The term "event" refers to the complete meeting, show or concours under the control of the Organisers. "Events" may include "competitions" for more than one "discipline"

The Federation: The Bahrain Royal Equestrian & Endurance Federation (BREEF) or National Federation (NF)

Guardian: A person, duly authorized to act on behalf of the person legally responsible for the underage individual.

Height: Pony height is up to and including 148cms without shoes. Horse height exceeds 148cms.

Horse: Refers also to a Pony or other member of the genus Equus unless the context requires otherwise.

Junior: A person may compete as a Junior from the beginning of the calendar season in which he/she reaches the age of Sixteen (16) until the end of the same season i.e., if 16 when registering with BREEF at the beginning of the season Oct-April, the person may ride as a junior throughout that same season.

Senior: A person may compete as a Senior when he/she reaches the age of Seventeen (17).

Judge: A member of the Judges' panel appointed by the Federation or be appointed by the Event Organising Committee. All must be qualified NF judges from Bahrain or abroad

Organisers: The Organiser or organising committee (OC) recognised by NF and responsible for organising any equestrian event.

Person Responsible: In all cases the rider is deemed to be the Person Responsible (P.R.)

Registered Person: Any paid-up person for the year current with BREEF

Rules: The Rules of Bahrain Royal Equestrian & Endurance Federation

Show Ground: The area in which the ring/arena, collecting ring, exercise/assembly areas, transport parks and stabling are situated.

Trainer: A person whose normal employment/appointment in the Kingdom of Bahrain is that of Dressage Trainer or a person officially appointed by NF to act as Official Trainer.

Year: The year commences on 1st January and ends on the 31st December, as per FEI.

Bahrain competition season: from October 1st to June 1st

SECTION II - GENERAL RULES

CHAPTER I: CODE OF CONDUCT

Article 105. Code of Conduct for the Welfare of the Horse:

1. In all equestrian disciplines the horse must be considered paramount.
2. The wellbeing of the horse shall be above all demands of breeders, trainers, owners, riders, dealers, Organisers, officials or any agent of such persons.
3. All handling and veterinary treatment must ensure the health and welfare of the horse.
4. The highest standards of nutrition, health sanitation and safety shall be encouraged and maintained at all times.
5. Adequate provision must be made for ventilation, feeding, watering and maintaining a healthy environment during transportation.
6. Emphasis should be placed on increasing education in training and equestrian practices and on promoting scientific studies in equine health.
7. In the interest of the horse, the fitness and competence of the rider, his groom or any other agent, shall be regarded as essential.
8. All riding and training methods must take account of the horse as a living entity and must not include any equipment or technique considered by NF or the FEI. to be abusive.
9. BREEF hereby establishes a control in order that all persons under its jurisdiction, their agents or guardians respect the welfare of the horse.
10. The National and International Rules and Regulations in equestrian sport regarding health and welfare of the horse must be adhered to not only during National and International competitions but also in training.
11. Compliance with this code of Conduct is a pre-requisite of all persons registered with BREEF, and their agents or guardians.

Article 106. Code of Conduct for Good Sportsmanship:

No Official, Owner, Rider, Trainer, Agent or Guardian at an event shall:

1. Argue with a Judge or Official or use abusive, threatening or unseemly language or behave with incivility or contempt towards a Judge or Show Official.
2. Conduct him/herself in a manner which is offensive to the public or detrimental to the character or prejudicial to the interests of NF.
3. Ill-treat a horse in any way whether inside or outside the arena.

4. Make remarks orally, in writing or on social media, about an officer of NF, the Jury, Judges or the Organiser, a statement on any matter covered by the Rules, which he knows to be untrue or slanderous.
5. Compete as owner or rider in a competition for which the horse or rider are not fully eligible.
6. Having started a competition, then willfully incur elimination.
7. Unreasonably refuse to assist NF at any inquiry.
8. Offend in any way the Codes of Conduct as published in this Rule Book.
9. Behave in a manner, which brings the Country, the Sport or NF into disrepute.
10. Any person who commits a breach of any part of this rule shall be deemed to be guilty of unseemly conduct and in respect of a breach of Article 106. Code of Conduct. They shall be eliminated from the competition by the Ground Jury or Senior Judge and/or referred to NF

CHAPTER II: DRESSAGE

Article 107. Object and General Principles of Dressage

The object of Dressage is the development of the Horse into a happy Athlete through harmonious education. As a result, it makes the Horse calm, supple, loose and flexible, but also confident, attentive and keen, thus achieving perfect understanding with the Athlete. These qualities are demonstrated by:

- The freedom and regularity of the paces.
- The harmony, lightness, and ease of the movements.
- The lightness of the forehand and the engagement of the hindquarters, originating from a lively impulsion.
- The acceptance of the bit, with submissiveness/thoroughness without any tension or resistance.
- The Horse thus gives the impression of doing, of its own accord, what is required. Confident and attentive, submitting generously to the control of the Athlete, remaining straight in any movement on a straight line and bending accordingly when moving on curved lines.
- The walk is regular, free and unconstrained. The trot is free, supple, regular and active. The canter is united, light and balanced. The hindquarters are never inactive or sluggish. The Horse responds to the slightest indication of the Athlete and thereby gives life and spirit to all the rest of its body.
- By virtue of a lively impulsion and the suppleness of the joints, free from the paralyzing effects of resistance, the Horse obeys willingly and without hesitation

and responds to the various aids calmly and with precision, displaying a natural and harmonious balance both physically and mentally.

- In all the work, even at the halt, the Horse must be “on the bit”. A Horse is said to be “on the bit” when the neck is more or less raised and arched according to the stage of training and the extension or collection of the pace, accepting the bridle with a light and consistent soft submissive contact. The head should remain in a steady position, as a rule slightly in front of the vertical, with a supple poll as the highest point of the neck, and no resistance should be offered to the Athlete.
- Cadence is shown in trot and canter and is the result of the proper harmony that a Horse shows when it moves with well-marked regularity, impulsion and balance. Cadence must be maintained in all the different trot or canter exercises and in all the variations of these paces.
- The regularity of the paces is fundamental to Dressage.

For more on particular movements please refer to the objects and principal of dressage guide available for download from: breefdressage.com/downloads

CHAPTER III: COMPETITIONS

Article 108. Recognition.

No competition shall be recognised by NF unless judged under NF Rules, or in the case of International Competitions, under the Rules of the FEI.

Article 109. Competition.

- Separate Competitions for the following standard categories of Athletes may be included in the schedules for all Events unless stated otherwise in the Rules:

109.1 Competition Levels.

Levels	Double/ Snaffle	Horse Age	NF Test	FEI Tests
Introductory	Snaffle	Min 4 Y/O	Intro 1 2023	N/A
			Intro 2 2023	
			Intro 3 2023	
Preliminary	Snaffle	Min 4 Y/O	Prelim 1 2023	Children Preliminary A
			Prelim 2 2023	4-year-old horse test
			Prelim 3 2023	
Novice	Snaffle	Min 5 Y/O	Novice 1 2023	Children Preliminary B
			Novice 2 2023	5-year-old horse test
			Novice 3 2023	
Elementary	Optional	Min 6 Y/O	Elementary 1 2023	Children team test
			Elementary 2 2023	Children individual test
			Elementary 3 2023	
Medium	Optional	Min 6 Y/O	Medium 1 2023	Pony rider Preliminary
			Medium 2 2023	Pony rider Team
			Medium 3 2023	Pony rider individual
Advance- Medium	Optional	Min 6 Y/O	Advance- Medium 1 2023	Reginal Games test (all)
			Advance- Medium 2 2023	6-year-old horse tests
			Advance- Medium 3 2023	Juniors' tests (all)
Advance	Optional	Min 7 Y/O	Advance 1 2023	Younge Riders Tests (all)

			Advance 2 2023	7-Year-Old Horse tests
			Advance 3 2023	
Small Tour Level	Optional	Min 7 Y/O	FEI tests	PSG
				Inter I
				Inter I Freestyle
Medium Tour Level	Optional	Min 8 Y/O	FEI tests	Inter A
				Inter B
				Inter II
				Inter A/B Freestyle
Big Tour Level	Double	Min 8 Y/O	FEI tests	GP
				GPS
				GP Freestyle

- Events may include other separate Competitions which must be specified on the Schedule and approved by NF, i.e., Separate Classes for Thoroughbred or Arabian horses
- Ponies are allowed in all competitions for children/juniors, and for Introduction and Preliminary levels of all age categories.
- Classes with less than 3 entries will still run and rosettes awarded.

Article 110: Levels of Competitions.

The National Dressage competitions are divided into following classes:

- Introduction Class
- Preliminary Class
- Novice Class
- Elementary Class
- Medium Class
- Advanced Medium Class
- Advanced Class

Article 111: Tests.

1. Each Competition has its own test. The Official Dressage tests are published on the authority of the NF and can in no case be modified or simplified without the approval of the NF. Tests are either NF or FEI.
2. The NF Tests can be downloaded at the homepage of NF: breefdressage.com/downloads
3. FEI tests may also be used in National competitions. Only the latest versions must be used. The tests can be downloaded at the homepage of FEI: fei.org
4. At National Events rising trot is allowed in Introductory, Preliminary, Novice and Elementary tests. Sitting trot is compulsory from Medium upwards apart from where it is stated in the tests.
5. Ponies are allowed in all competitions for Juniors and for Senior Levels of Introduction and Preliminary tests.

Article 112: Execution of the Test.

1. After the sound of the bell, the Athlete must enter the arena at A within forty-five (45) seconds. In the Freestyle, the Athlete has forty-five (45) seconds to signal to start the music and must enter the arena within thirty (30) seconds of the music starting. During Freestyle tests, in case of technical failure or delay in start of the music, the Judge at C can interrupt the count and re-continue after the problem has been resolved. The Judge at C is responsible for the bell and clock/time.

- In the event that the Horse starts to defecate or urinate after the judge rang the bell, but before the start of the test, the clock will be stopped until the Horse is ready to continue at which point the clock will be restarted.

- Entering the Arena: For Competitions where it is not practical for the Athletes to ride their Horses around the outside of the arena prior to entering the arena, Athletes are permitted to enter the arena before the bell is sounded. After the bell has sounded, the Athlete starts the test from within the arena.

2. Salute. Athletes must take the reins and whip (if used) in one hand at the salute, then lower the free hand to their side and nod their head. An incorrect salute or no salute will incur a penalty of 0.5% (zero-point five percentage points) deducted per each failed execution by each judge.

3. Error of course. When an Athlete makes an "error of course" (takes a wrong turn, omits a movement, etc.) the Judge at C warns him, by sounding the bell. The Judge at C shows the athlete, if necessary, the point at which they must take up the test again and the next movement to be executed, then leaves them to continue by themselves. However, in some cases when, although the Athlete makes an "error of course", the sounding of the bell would unnecessarily impede the fluency of the performance - for instance if the Athlete makes a transition from medium trot to collected walk at V instead of at K, or, cantering up the center line from A, makes a pirouette at D instead of at L - it is up to the Judge at C to decide whether to sound the bell or not. However, if the bell is not sounded at an error of course and the test requires the same movement to be repeated and the Athlete again makes the same error, the Athlete is only penalised once.

The decision as to whether an error of course has been made will be at the sole discretion of the Judge at C. The other Judges' scores will be adapted accordingly.

4. Error of Test/Execution. When an Athlete makes an "error of the execution of the test" (trots rising instead of sitting, etc.) the athlete must be penalised as for an "error of course". In principle, an Athlete is not allowed to repeat a movement of the test unless the Judge at C decides on an error of course (sounds the bell). If, however, the Athlete has started the execution of a movement and attempts to do the same movement again, the Judges must consider the first movement shown only and at the same time, penalise for an error of course.

5. Unnoticed Error. If the Ground Jury has not noted an error, the Athlete has the benefit of the doubt and will therefore not be penalised for the error.

6. Penalties

6.1. "Error of Course" and Error of Test/Execution:

Every "error of course" or error of test/execution, whether the bell is sounded or not, must be penalised, except as noted above.

- First error – deduction of 0.5% from the total score
- Second error – deduction of 1% from the total score
- Third error – Elimination

6.2. Other Penalties – Technical Faults:

It is the responsibility of the Judge at C to decide whether a penalty should be applied and the other judges' sheets should be marked accordingly to ensure consistency.

All of the following are considered technical faults, and zero-point five percentage points (0.5%) will be deducted per fault by each Judge, but these deductions are not cumulative and will not result in Elimination (including for Freestyle tests):

Description of Technical Fault	Comments
Entering the space around the arena with a whip (when the use of a whip is not permitted) or with boots/bandages on the horse's legs or with discrepancy in Athlete's dress (e.g., lack of gloves)	
Entering the arena before the sound of the bell or beginning the test before the sound of the bell if starting from inside.	If the test has already started before the discrepancy has been noticed, the Judge at C stops the Athlete and if needed and possible, an assistant may enter the arena to remove the item(s). The Athlete then continues the test, from the movement where they were stopped. The marks given before they were stopped are not

	changed
Not entering the arena within forty-five (45) seconds after the bell, but within ninety (90) seconds.	
For freestyle tests, entering the arena after more than (30) seconds of music.	
Using voice or clicking the tongue repeatedly.	
Athletes not taking the reins in one (1) hand at the salute.	
Leaving the competition area for any reason.	First time- minus 1% Second time- elimination

If the Freestyle test is longer or shorter than stipulated on the test sheet, zero-point five percentage points (0.5%) will be deducted from the total Artistic score, for other technical faults zero-point five percentage points (0.5%) will be deducted per fault from the technical score.

Penalty Percentage Points: the penalty percentage points are deducted on each Judge's sheet from the total points obtained by the Athlete.

7. Reasons for Elimination:

a. Lameness. In a case of marked lameness, the Judge at C informs the Athlete that they is eliminated. There is no appeal against this decision.

b. Resistance. Any resistance which prevents the continuation of the test longer than twenty (20) seconds is punished by Elimination. However, resistance that may endanger an Athlete, Horse, judges or the public will be result in elimination for safety reasons, earlier than within twenty (20) seconds.

This also applies to any resistance before the entering the Dressage arena.

c. Fall. In the case of a fall of a Horse and/or an Athlete, the Athlete will be Eliminated.

d. Leaving the Arena During the Dressage Test. A Horse leaving a completely closed arena (gate at A), with all four (4) feet, during a Dressage Test between beginning and end of the test will be penalized for the first offence and Eliminated for a second offence.

e. Outside Assistance. Any non-permitted outside help by voice, signs, earphones and/or electronic communication devices is considered illegal

or unauthorized assistance to an Athlete or to their Horse. Illegal or unauthorized assistance will result in Elimination of that combination.

f. Bleeding: If the Judge at C suspects fresh blood anywhere on the Horse during the test, they will stop the Horse to check for blood. If the Horse shows fresh blood, it will be eliminated. The elimination is final. If the Judge thoroughly examines the Horse and clarifies that it has no fresh blood, the Horse may resume and finish its test.

g. Other Reasons for Elimination:

- The performance is against the welfare of the Horse and/or shows abusive riding.
- Horse and Athlete combination not entering the Competition arena within ninety (90) seconds after the bell. Except where a valid reason thereto has been informed to the Judge at C (valid reason may be losing a shoe, etc.)
- Riding with non-permitted equipment which is not covered under these Rules.

8. Execution of Movement at Certain Point.

In a movement, which must be carried out at a certain point of the arena, it should be done at the moment when the Athlete's body is above this point, except in transitions where the Horse approaches the letter from a diagonal or perpendicular to the point where the letters are positioned. In this case, the transitions must be done when the Horse's nose reaches the track at the letter so that the Horse is straight in the transition. This includes the execution of flying changes.

9. Beginning/End of Test. A test begins with the entry at A and ends after the salute at the end of the test, as soon as the Horse moves forward. Any incidents before the beginning or after the end of the test have no effect on the marks. The Athlete should leave the arena in the way that is prescribed in the text of the test.

10. Details for The Freestyle Test. An Athlete must enter the arena within thirty (30) seconds of the music starting. At the beginning and end of a Freestyle Test a halt for the salute is compulsory on the centerline facing the Judge at C. The test time will start after the Athlete moves forward after the halt and stop with the final salute.

Article 113: Time and Technical Failure.

1. Timing of Tests: only Freestyle tests are timed. The time shown on all other test sheets is informational only. The Judge at C is responsible for bell and clock/time. A clock showing forty-five (45) seconds, should be used whenever possible, and should always be clearly visible for the Athlete.

2. Interruption:

- In case of any technical failure that will interfere with the test, the Judge at C shall ring the bell. It is recommended that in clear cases of external disturbances, the same procedure is applied. During extreme weather conditions or other extreme situations, the Judge at C may ring the bell for interruption of the test. The Technical Delegate/OC may also suggest to the Judge at C to stop the Competition. The affected Athlete should return to complete their test when conditions so permit.
- During Freestyle tests, in case of technical failure or delay in start of music, the Judge at C can interrupt the count and re-continue after the problem has been resolved.
- In the case of an Athlete's music failing during a Freestyle Test and in cases where there is no back-up system, the Athlete can, with the permission of the Judge at C, leave the arena. There should be minimum interference with the starting times of the other Athletes. The affected Athlete should return to complete or restart their test during a scheduled break in the Competition or at the end of the Competition. The Judge at C, after conferring with the Athlete, will determine when the Athlete should return to the arena. It is up to the Athlete whether to restart the test from the beginning or to commence from the point where the music failed. In either case, the marks already given will not be changed.
- If there are foreign objects in the arena which could have an influence on performance, the test must be stopped and the Athlete can continue once the object has been removed.
- If an Athlete must restart a Freestyle test, they can choose to start from the beginning or where they stopped. In any other test, the Athlete must restart from where they were stopped unless the Athlete was required to leave the arena and warm up again, in which case the Athlete must be given the option to start their test from the beginning or from where they were stopped. Any scores given before the interruption remain

Article 114: Judges' Sheets.

1. General:

- a. The Judges' sheets have two (2) columns: the first for the Judge's original mark, the second for the corrected score. Any corrected score must be signed by the Judge having made the correction. Judges' scores must be endorsed by the Judge. After the Judge signs and gives away his Judge's sheets the marks can no longer be changed.
- b. There is also a column for the Judge's remarks, where the Judge as far as possible, should state the reason for the judgment. Giving remarks is compulsory, when giving marks of 5.5 and below. Judges' sheets should be available to the Athletes after the class.
- c. The final results of the class must be signed by the Senior judge and the Chief Scorer.

2. Markings:

- a. All movements, and certain transitions from one movement to another and Collective Mark, which have to be marked by the Judges, are numbered on the Judge's sheet.
- b. They are marked from zero (0) to ten (10) by each Judge, zero (0) being the lowest and ten (10) the highest mark. All half marks from 0.5-9.5 may also be used both for movements and collective mark, at the discretion of the judge.

- c. The scale of marks is as follows:

10	Excellent	7	Fairly Good	4	Insufficient	1	Very Bad
9	Very Good	6	Satisfactory	3	Fairly Bad	0	Not Executed
8	Good	5	Sufficient	2	Bad		

"Not Executed" means that practically nothing of the required movement has been performed.

3. Collective Marks:

- a. After the Athlete has finished their performance, a collective mark is awarded for General impression. In Introductory, Preliminary, Novice and Elementary collective marks are also awarded for athletes' position, effectiveness of aids, precision and general impression.

- b. The Collective Mark and certain difficult movements can be given a coefficient fixed by the FEI or NF.

Article 115: Results and Calculation of Scores.

After each performance and after each Judge has given their collective mark and signed the sheets, these are passed into the hands of scorers. The marks are multiplied by the corresponding coefficients, where applicable, and then totaled. Percentages are given with three decimal places

1. Individual Classification: The individual classification is decided as follows: In all Competitions the winner is the Athlete having obtained the highest total percentage, the second placed Athlete is the one with the next highest total and so on.

2. Ties:

- In case of equal total score, where there is a difference in the collective marks, the higher of the collective marks will decide placing.

If both the total score and collective scores are equal, all riders within the tie will share the allocated placing and the subsequent placing will be removed. Each rider within a tie will receive where applicable rosettes of the allocated placing and share the combined prize money for both places.

- Ties in Freestyle: In case of equality of percentage in a Freestyle Test for the first three (3) places, the higher artistic marks will decide on the better placing. Should the artistic mark be the same, the higher mark for harmony will decide. If still tied the higher mark for choreography will decide. If still tied, then both Athletes are given the same placing.

If an athlete fails to compete, the reason must be written after the athlete's name on the scoresheet

Retired: The Athlete started the test but abandoned at some point within the test.

Eliminated: The Athlete has started, but had to end the performance due to a breach of the Dressage Rules.

No Show: The Athlete did not present for the test, without further information.

Withdrawn: The athlete did not present the test, with reasoning presented.

Article 116: Entries.

1. Organisers will make appropriate arrangements to invite participants for each level of competition included in the event's schedule. Such entries will then be forwarded to NF who will ensure that all eligible horses and riders can enter.
2. Closing dates for NF events will be stated on the Schedule, or it will be four (4) days before the event. Entries received after the closing date prior to an event may not be accepted.
3. Entry Fees will be set by the NF and will be clearly marked on the Schedule.
4. Entry Fees are to be paid on entry and before the start list of the event is published. Failure to do so will incur elimination from the event and the athletes name will be removed from the start list
5. Any cancellation or withdrawal completed less than 24 before the start of the event will be subject to a 50% penalty. This penalty shall be waived if a veterinary note is presented to the OC within that 24-hour period prior to the competitions' start. If a rider registers for a competition, does not cancel within the stipulated time limit and does not compete on the day, all of the entry fee will be forfeited to offset the event running costs.
6. Under no circumstances will an athlete be allowed to compete if entry fees have not been paid
7. Start Lists will be published and sent out via WhatsApp Dressage Group Chat by 12pm one day before the competition by a Group Chat Admin. Substitutions will be at Show Organisers' discretion for National Events.
8. All Classes with less than 3 entries will still run however only rosettes will be awarded

Article 117: Schedules.

All schedules must have the given date and location of the Event and the dates by which entries must be received in accordance with the following check list:

1. The words "Bahrain Royal Equestrian & Endurance Federation Competition" or "BREEF"
2. The Disciplines in which Competitions will be held
3. The program of Competitions
4. The category of eligibility according to NF rules
5. Location of the competition
6. The stabling and accommodation available

7. The value of the prizes and their distribution with the actual break down of each placings in each class
8. The national veterinary health requirements
9. Any other relevant details, such as whether café/food services are available.
10. The Schedule must also give the time and place of the commencement of the Horse inspection under the Veterinary Regulations if this will be held.

Article 118: Organisers.

1. The Organisers must appoint all Judges and Officials from NF list for national events or approved judges from other countries, or FEI judges.
2. For FEI International Events, NF will appoint Officials from the FEI recommended list and cover the costs of international Judges and Officials.
3. The Organisers must submit to the Secretary General of NF within five (5) business days of completion of the event, the following in respect of each competition:
 - a. A list of all starters, together with their results.
 - b. Lists of all placings should be signed by the Senior Judge and the Chief Scorer (National Events) or two members of the Ground Jury (International Events) of the Competition.

Article 119: Arena and Exercise Arenas (For Diagram see annex arena).

1. At National NF events and National Championships, the competition arena must be inspected and approved by The President of the Ground Jury (highest qualified judge of the day).
2. Arena Specifications: The arena; flat and level, must be either sixty meters (60 m) long and twenty meters (20 m) wide or forty meters (40 m) long and twenty meters (20 m) wide. The arena surface shall be approved by the NF. The measurements above are for the interior of the enclosure, which must be separated from the public by not less than ten meters (10 m). Exceptions from this may be granted by the NF.
3. The enclosure itself must consist of a low white fence (rails which must not be solid), thirty centimeters (30 cm) high. The section of fence at 'A' should be easy to remove, to let the Athletes in and out of the arena. The width of the entrance must be at least two meters (2 m). The rails of the fence should be such as to prevent a horse's hoofs from being caught. The rails may not contain any metal components.

4. It is recommended to keep the part of the fence at A closed during each Athlete's performance and between tests, until the Judge at C gives the starting signal.

5. Letters: The letters outside the enclosure shall be placed about fifty centimeters (50 cm) from the boards and clearly marked. Advertising is not allowed on letters or on letter holders. Letters should also be visible for the public.

6. Placing of Judges: Head Judge to be placed at C with a minimum of 3m from the side of the arena but no more than 5m. In the case of multiple judges, the following is true:

2 Judges – C & B/E, 3 Judges- C, B/E & M/H. For more judges, please review FEI Rules

9. Entering the arena: For Competitions where it is not practical for the athletes to ride their horses around the outside of the arena prior to entering the arena, athletes are permitted to enter the arena before the bell is sounded. After the bell has sounded, the athlete starts the test from within the arena.

a. In competitions where it is possible to ride a horse around the outside of the arena, the athlete is allowed to enter the space around the arena before the bell is sounded but may only enter the arena after the bell has been sounded.

b. The Judge at C is responsible for bell and clock/time.

10. Warm-up Arena: On no account and under penalty of disqualification, may an Athlete/Horse use the competition arena at any time other than during their performance in a competition or when at the discretion of the OC the main arena is open for training. A suitable size warmup arena must be provided and approved by the NF.

11. Interruption: refer to Article 113.2

Article 120: Medical and Veterinary Services.

In compliance with BREEF no event may commence without the presence of Medical Services. Show Organisers are therefore obliged to ensure that Medical Services, together with Treating Veterinary Services are present prior to and throughout their event.

Article 121: Starting Possibilities.

1. Rider/Horse combination: A rider/horse combination can start in two different classes but with no more than one level difference, i.e.: Intro-Preliminary, Preliminary-Novice, Novice-Elementary, Elementary-Medium, Medium-Advanced Medium, Advanced Medium-Advanced

2. Rider: A rider can start:

- a. In different classes – with no more than one level difference if on the same horse.
- b. In the same class but with different horses
- c. The OC may restrict the number of entries from a rider if the total number of entries for the class exceeds the possible maximum number of participants.
- d. in different classes with different horses

2. In all National Competitions at Preliminary, Novice levels the horse may be ridden by one other competitor.

3. Horse: A horse is allowed to start:

- a. Not more than three (3) times per day with different riders if competing in Introductory only
- b. Not more than twice (2) times per day in Preliminary and above or when riding multiple classes
- c. Once a day on small, Medium Tour and Big Tour level.

Article 122: Identification.

Where registration numbers are issued to competitors the correct numbers must always be worn by the horse when taking part in competitions and during the Show.

Article 123: Hors Concours (HC).

1. A Horse and or Rider that is permitted to take part in a competition Hors Concours by the NF will not be eligible for any prize or points in that class.
2. Hors Concours are permitted up to Prix St. George level with permission from the NF.
3. Horse and or Rider may compete without full registration with NF during a season as HC with the approval of the NF and the organising Committee.

4. A horse or pony may not be ridden competitively in a class if it has already been ridden Hors Concours by another rider in the same competition.

Article 124: Callers.

1. Callers can be used in the following classes for National Competitions: Introduction, Preliminary, Novice and Elementary levels.

2. Callers are forbidden at National Championships or FEI International Challenge/Championships.

Article 125: Warming-Up.

1. At FEI International Dressage Competitions, Regional and National Championships it is prohibited under penalty of elimination for anyone to school a horse other than the person riding in the competition.

2. In all National competitions, the horse may not be ridden by another person other than the competitor. If one horse is being shared by multiple competitors, only the rider who is competing in the current active class may ride the horse to warm up as per their running order.

3. Warming-up activities by another person other than the competitor shall be restricted to lunging, or hand walking.

4. Warming-up with a contact and/or schooling the horse by another person than the competitor is not allowed under penalty of elimination

5. All warming-up activity is to be done within line of sight of the steward.

6. If the warm-up arena is becoming overcrowded those not competing on the ongoing class may be asked to leave the arena. If so necessary, the Steward or Senior Judge can limit the number of horses in the warm-up arena so that each horse has a minimum of 45 minutes to its allocated starting time.

7. Coaches who train riders during warm-up must stand either outside the fence or in a corner of the riding arena and not disturb other riders.

8. Coaches and Riders may use electronic devices while in the warmup arena, the Rider must remove their devices prior to entering the area around the competition arena. Failure to do so will result in Elimination.

9. Removal of boots, putting on jackets, removing electronic devices, etc. Should be done at the edge of the warm up arena so as not to interfere with other riders.

Article 126: Unforeseen Circumstances.

1. Every eventuality cannot be provided for in these Rules. In any unforeseen or exceptional circumstances, it is the duty of the Ground Jury or Senior Judge to make a decision in a sporting spirit and approaching as nearly as possible to the intention of these Rules.
2. In the event of any ambiguity with the interpretation of NF Rules, the current FEI Dressage Rules published in English language will take precedence over versions in any other language.

CHAPTER IV: THE BAHRAIN ROYAL EQUESTRIAN & ENDURANCE FEDERATION CHAMPIONSHIPS

Article 127: Place and Date.

The BREEF Championships in Dressage take place at the end of each season.

Article 128: Entry Qualification.

1. For the Introductory, Preliminary, Novice and Elementary classes, all Rider/Horse combinations who maintained an average of 65% or higher as well as combinations that attended a minimum of 2 shows will qualify. All combinations at Medium or higher will automatically qualify.
2. Where a horse has qualified with more than two riders the combinations of horse and rider that maintained the higher percentages will be given preference to compete, entries are subject to article 121.3.
3. Should the rider with the higher percentage choose not to compete on this horse the next highest placed combination on the horse may do so. At the discretion of the riders but subject to article 121.3.
4. Only the combinations that meet qualification requirements will be permitted to compete and no rider substitutions will be permitted for Championships.

Article 129: Competitions in the National Championships.

Championships will be held in the following Competitions:

1. Introductory Class- Junior and senior
2. Preliminary Class – Junior and Senior
3. Novice Class
4. Elementary Class
5. Medium Class
6. Advanced Medium Class
7. Advanced Class

The top five (5) riders from classes 2-7 will qualify for the freestyle for their level.

- Preliminary Freestyle
- Novice Freestyle
- Elementary Freestyle
- Medium Freestyle
- Advance Medium Freestyle
- Advanced Freestyle

CHAPTER V: FEI WORLD DRESSAGE CHALLENGE SELECTION/QUALIFYING RULES

[FEI World Challenge](#)

CHAPTER VI: CEREMONIES, PRIZES AND EXPENSES

Article 130: Ceremonies.

1. Participation in the Prize-Giving ceremony of placed Athlete/Horse combinations is compulsory. Failure to do so entails losing the classification and prizes (rosette, plaque, prize in kind and prize money). Exception to this rule can only be granted by the Senior Judge (National Competitions) or President of the Ground Jury/Foreign Technical Delegate and /or the Judge at C or Chief Steward (International Competitions) for the particular Competition.
2. Competitors are obliged when required to parade mounted or unmounted.
3. Dress and saddlery must be the same as in the competition. However, black, or white bandages, boots, earplugs on horses and carrying a whip are allowed. For safety reasons, Athletes are not allowed to carry flags or other items during prize giving.

Article 131: Prizes.

1. Refer to Article 117. Schedules to show required information.
2. The amount of Prize Money and type and value of prizes if in kind, must be stated in the schedule and is unrestricted.
3. The distribution of prizes and prize money is up to the organising committee and/ or sponsor
4. In the case of ties, subject to article 115.2.
5. With the consent of NF additional rosettes may be awarded for competitions during an event.
6. Organisers are encouraged to award rosettes up to at least 6th place for National Events.
7. In the case a class has less than 4 starters. A minimum of 1st place rosette should be awarded

Article 132: Expenses.

The OC shall meet the travelling, accommodation, and meals Expenses of all international officials.

1. NF appointed Officials whose Expenses are to be paid by the OC shall be appointed with the agreement of the OC.

CHAPTER VII RIDERS

Article 133: General.

Riders include both female and male athletes.

Article 134: Registration – Riders.

1. To be eligible to compete, all riders must be registered with NF.
2. The final decision regarding registration remains solely and exclusively with NF.
3. Registration Fees will be set by NF.

Article 135: Person Responsible.

1. Person Responsible: In all matters the Person Responsible (P.R.) will be the rider. As per FEI General Regulations.
2. If a rider is under 18 years of age, the Person Responsible (P.R.) for his horse must be nominated by NF or Chef d'Equipe and may be the Owner of the horse, a Parent of the rider in question, Team Coach, Team Veterinarian, or some responsible Adult. If NF and/or Chef d'Equipe fail to nominate the P.R. anyone or more of the Owner of the horse, a Parent of the rider, the Chef d'Equipe, Team Coach and or Team Veterinarian may be viewed as the P.R.
3. In some circumstances, the Legal Department may be able to establish that a minor is involved, but the determination and the designation of the P.R. for such a minor remain the responsibility of NF and the relative Club Manager.
4. However, in addition to the above and in certain circumstances, NF may consider that some or all of the responsibilities rest with the Owner, relative Club Manager, Official Trainer and/or Official Veterinary Surgeon. In such cases, NF may also, if appropriate, apportion responsibility/liability to any of them.
5. The term 'Official' necessitates verifiable appointment by NF or Club relative to appointee in question, having been made and authorized by NF or Club relative prior to competition involved.

CHAPTER VIII: HORSES

Article 136: Eligibility.

1. Only horses, which are registered with NF, are eligible to compete at Events run under the Rules of NF. (Hors Concours included)
2. NF may, at its sole discretion, permit foreign riders/horses (i.e.) those affiliated to a foreign Federation) to compete in national competitions subject to the following conditions:
3. Written application for such permission is received by NF from Foreign Federation.
4. Full documentation is received by NF in respect of registration of both horse and rider.

Article 137: Registration – Horses.

1. All horses entered in events must be registered with NF.
2. No horse under 4 years of age may be registered.
3. To secure registration the owner is obliged to provide the NF with Identification Documents and with up-to-date equine influenza vaccination details, both completed by a qualified and NF approved veterinary surgeon.
4. Bahrain Royal Equestrian and Endurance Federation will keep a register of horses showing full details.

Article 138: Horses Name.

1. Horses must only be registered, entered, and compete in competitions under their registered names.
2. Should an owner wish to change a horses' name; an application must firstly be made to BREEF for authorization and subsequent amendment of the register.
3. Animals holding FEI passports will be registered with and may only compete under their FEI registered names.

Article 139: Horses – Age.

1. Horses may compete if they are a minimum of:

- 4 years of age for Introductory, Preliminary & Novice
- 5 years of age for "Adults" Preliminary to Elementary
- 6 years of age for Medium to Advanced
- 7 years of age to PSG
- 8 years of age in Intermediate II to Grand Prix

2. The age is counted from 1st January of the year of birth

Article 140: Competitive Conditions.

The P.R., parent or guardian is responsible for the welfare of their horse competing at an event. The senior judge, where appropriate after consultation with a veterinarian, can give permission to start or eliminate a horse if the level of performance, fitness, injuries, or general condition is detrimental to the welfare of the horse or the sport's reputation.

CHAPTER IXI: DRESS

Article 141: Article Dress Code – General.

1. Competitors must wear the dress appropriate to Dressage and be properly dressed when appearing before spectators, media or whenever they are in the confines of the arena and at presentation of prizes.
2. In very warm weather, the Jury or Senior Judge may permit competitors to remove their jackets and stocks along as the Athlete is wearing an appropriate white or light coloured show shirt.
3. If competitors are not properly dressed, they will be eliminated except for technical faults as mentioned in Article 113, by the Ground Jury.

Article 142: Advertising.

Competitors or their horses are not permitted to carry or wear any form of advertising material while in the arena, unless specifically permitted by NF. (Ref. Art. 149)

Article 143: Jacket/Coat.

1. From Novice to Medium Level – National Service Dress or Short Jacket with correctly tied stock or collar shirt and tie and protective head gear is compulsory. The stock or tie to be white, off white.
Stock or tie is optional from Introductory to Elementary Level.
2. Advanced Medium and above – Tailcoat with protective hat or National Service Dress to be worn with protective hat.
3. National Service Dress, Tailcoats or short Jackets to be worn and may be of any plain single colour
4. National Riders eligible to wear NF Uniform may do so with permission from NF. National Riders competing in FEI International events are obliged to wear the Official NF uniform.
5. At the discretion of Organisers, competitors may be permitted to ride without jackets and stocks/ties in excessively hot weather, but a suitable long/short sleeved shirt that fastens at the neck. No sleeveless shirts or vests are permitted.

Article 144: Hats.

1. As a general rule, a properly fastened Protective Headgear has to be worn by all Athletes at all times when mounted and by Juniors and U18 for the Horse inspection.
2. Any Athlete violating this provision must immediately be prohibited from further riding until the protective Headgear is properly in place.
3. During Horse inspections protective headgear is optional for adults but always recommended.
4. If any Athlete chooses to remove their Headgear at any time, whether permitted or not, such removal shall always be entirely at their own risk.

Article 145: Breeches/Jodhpurs.

1. Must be plain white, off-white, or cream.
2. When worn with National Service Dress they may be of the colour of the National Service Dress.

Article 146: Gloves.

1. Gloves must be worn, and shall be white, off-white, or in lower levels Dark colours are permitted. If gloves are not worn there will be a 0.5% deduction on the scoresheet.

Article 147: Boots.

1. Must be plain black or brown or any other dark colour, may be tall boots or jodhpur boots for National Competitions.

2. Half chaps may be worn in all National Competitions up to Elementary Level provided that they are identical leather to the boots and may not have any decoration of any sort.

3. Boots worn from medium level and up or in FEI International Dressage Competitions must comply with current FEI Dressage Rule Article 431.

Article 148: Spurs.

1. Spurs may be worn at all levels and are compulsory from medium level upwards.

2. Junior riders, in Junior classes, spurs are optional but if used, only blunt metal spurs no longer than 3.5cm in length, measured from the boot to the tip are allowed. Spurs with rowels are not permitted.

3. When Junior riders compete in adult classes they compete under the same regulations as for the seniors.

4. The spurs must be made of metal. The shank must be either curved or straight pointing directly back from the center of the spur when on the Athlete's boot. The arms of the spur must be smooth and blunt. If rowels are used, they must be blunt/smooth and free to rotate. Metal spurs with round hard plastic nobs are allowed ("Impulse" spur). "Dummy" spurs with no shank are also allowed.

Article 149: Whips.

1. For National competitions, whips may be used at all levels up to Medium.

2. For National Championships or FEI International Events whips are forbidden. The whip must be dropped before entering the space around the Competition arena or the Athlete will be penalized.

3. If whips are carried, they must not exceed maximum length 1:20m. Refer to current FEI Dressage Rule 434.4 for description of whips permitted to be used.
4. Junior riders competing in National Competitions on Ponies (up to & inc.148cms) may carry a whip not exceeding 1m. Showjumping whips are not permitted.
5. No substitute for a whip may be carried in or around the vicinity of the show ground. Whips may be carried in either hand, but only in the left hand when saluting.

Article 150: Earphones.

Earphones and/or other electronic communication devices are strictly prohibited at National Dressage Competitions whilst competing and such usage is penalised by elimination. Earphones or similar devices are however permitted during training and warm- up.

CHAPTER X: SADDLERY

Article 151: Saddles.

1. Saddlery and equipment must conform to these General Rules and to the special rules for each discipline and with current FEI Dressage Rules. Saddles must be worn and be of English Style and must be black or brown for National events.
2. This may include all types of saddles gp, close contact, VSD or dressage. Up to Elementary level, a jumping saddle is permitted but without showjumping attachments e.g., breastplate.
3. The use of cruppers is permitted.
4. At medium level and above, dressage saddles must be used.
5. Seat Savers or saddle covers are not permitted.
6. Stirrups must have closed branches with no attachments. The foot may not be fully or partially enclosed and must in no way be attached to the stirrups (for example with magnets or a grater style surface). Safety stirrups may be used and can have an opening on the outside branch. Side stirrups are now permitted.

Article 152: Saddle Clothes.

1. Saddle pads should be white, contrast colour and piping is allowed. Striped or multi- coloured pads are not permitted.

Article 153: Logos.

1. Logos may be worn but not exceed 200cm square (approx. 14cm x 14cm or equivalent). Club logos are permitted but must not exceed 200cm square at National competitions.

Article 154: Bridles and Bits.

1. Events run under National Rules at Introductory, Preliminary and Novice, level – ordinary snaffle.

See chart for full description of permitted bits, Appendix 1.

2. Events run under National Rules at Elementary to Grand Prix level snaffle or double bridle.

See chart for full description of permitted bits, Appendix 1

3. Nosebands are obligatory.

See chart for full description of permitted nosebands, Appendix 2.

4. Bridles must be black or brown in colour and reins must be attached directly to the bit.

5. Bit guards are not allowed.

6. A throat lash is required except when the combined noseband or Micklem bridle are used.

7. Events run under FEI Competitions refer to current FEI Rules.

8. Bridle numbers must be clearly displayed on left side of bridle.

Article 155: Gadgets.

1. Martingales, breast plates, bit guards, any kind of gadgets (such as bearing, side, running or balancing reins, nasal strips etc.), and any form of blinkers, including ear plugs and any others, are, under penalty of elimination. This also applies to warming up prior to the competition.

2. Earplugs on Horses are forbidden but are allowed at Horse Inspections and Prize Giving Ceremonies only for safety reasons. Random checks will be

conducted during the equipment check at the end of the test and contravening this rule will incur Elimination.

Article 156: Decorations.

1. Any decoration of the Horse with extravagant items, such as ribbons or flowers, etc. is strictly forbidden.
2. A red ribbon in the tail, to indicate kicking is permitted.
3. Normal plaiting of the horse's mane and tail is compulsory for unhogged manes
4. Using glitter spray is permitted.
5. It is not allowed to paint any part of the Horses' body. It is strictly forbidden to use any type of substance (like "marshmallow fluff", shaving cream, etc.) around the Horses' mouth to imitate foaming; contravening the rule will entail Elimination.
6. Fly masks are forbidden in the Competition arena but may be allowed in warmup and training arenas at the discretion of the Senior Judge or President of the GJ.

Article 157: False Tail/Tail Extensions.

1. False Tails / tail extensions are permitted.
2. False tails may not contain any metal parts (except for hooks and eyelets), or extra added weight.
3. Random checks will be conducted during the equipment check at the end of the test and contravening this rule will incur a Warning.

Article 158: Ear Hoods.

1. Ear hoods are permitted for both indoor and outdoor venues and may also provide noise reduction but not noise elimination (no silicon ear hoods)
2. The ear hoods should be discreet in colour and should not cover the Horse's eyes and cannot be used for masking noise canceling earplugs.
3. Ear hoods may not be attached to the noseband.
4. If Ear Hoods are worn, they will be checked by the Steward and after being removed by the rider or groom.

5. Random checks will be conducted during the equipment check at the end of the test and contravening this rule will incur a Warning.

Article 159: Checking of Saddlery.

1. A Steward must be appointed to check the saddlery of each Horse immediately after it leaves the arena. Any discrepancy will be reported to the Judge at C and result in immediate Elimination if confirmed.
2. The checking of the bridle must be done with the greatest caution, as some Horses are very touchy and sensitive about their mouths (see FEI Steward's Manual). The Steward must use disposable surgical/protective gloves when checking the bridle (a new pair of gloves must be used per Horse).

Article 160: Saddlery and bits in the warming-up and training arenas.

1. In addition to the above with regards to saddlery and bits, snaffles with a cavesson or a normal dropped noseband, Mexican noseband or a Flash noseband, boots, and bandages are allowed.
2. For FEI Competitions refer to current FEI Rules.
3. Single direct side reins or double sliding side reins (triangle) are permitted when lunging. Lunging is allowed with one (1) lunge line only.

CHAPTER XI: GRADING SYSTEM

Article 161: Grading Average:

1. Grading averages over a season will be calculated for all Horse and Rider combinations who have completed 2 or more competitions. An average of all results will be used.

Article 162: Grading/Upgrading Horse rider combinations.

1. Grading/Upgrading of combinations will be decided by the following scale:
2. Introductory level – horse and rider combinations with a grading average of 66% over the previous season will need to move up the next season. Riders (not combination specific) who have scored 67% and above in any preliminary tests or ridden at novice level and above are not allowed to enter Introductory classes.

3. Preliminary level and above- horse and rider combinations with a grading average of 67% over the previous season will need to move up to the next season.

a. Should a horse and rider combination achieve a grading average of 67% over the previous season in multiple levels, they will only be expected to move up 1 level.

4. Competing in previous level after upgrading – Combinations than have been upgraded may compete in classes 1 level higher and 1 level lower provided they have an entry in their current graded level subject to article 121.1

Article 163: Downgrading of Horse and rider combinations.

1. Upon registration, a horse maybe downgraded via the following options:

a. If the combination has not competed for one full season the combination may be downgraded by one level, subject to article 163.2

b. The combinations grading average over the previous season is 60% or lower.

Article 164: Grading of Riders.

1. Riders who have competed at medium level and above shall not compete in preliminary classes.

2. However, should the same Rider have a young horse (4yrs old only) that they are bringing through, they will be permitted to ride Prelim on that young horse.

CHAPTER XII: SAFETY

Article 165: Horse out of control.

The judge may stop the performance, eliminate, deny rider or others to ride the horse on the show ground if it is a danger to the Rider, Horse, or other horses and people.

Article 166: Disobedience.

1. During the test: If the horse is disobedient more than 20 sec continuously it will be eliminated by the Judge sitting at C.
2. During the warmup and the entire competition: Resistance that may endanger the Athlete, Horse, or others around will result in elimination for safety reasons. The Athlete will be asked by an Official to dismount and leave the arena.

Article 167: Dangerous situations.

When a horse/rider combination is experiencing extreme difficulty or is considered to be a danger to themselves or others, Competition Officials and/or GJ may, at its sole discretion and following extensive enquiries and consultation with owner/rider/trainer, direct that a particular course of action must be taken by the owner/rider. Such directions may include the following:

- a. Abstention from competition and training to rectify the problems, or any other course of action, which in the opinion of BREEF/OC might resolve the situation.
- b. Club Managers are required to carefully monitor the competence/suitability of their riders/horses.

CHAPTER XIII: PROTECTION OF ATHLETES AND HORSES

Article 168: Protection of Athletes.

1. Whenever mounted on the show grounds the use of a properly fastened Protective Headgear will be mandatory. In the Competition arena and adjacent warm-up areas, as well as riding from one to the other and from the stables for the purposes of competing, the Protective Headgear requirements are governed by Art. 145.
2. Failure to wear such Protective Headgear as and when required after being notified to do so by a Competition Official, shall result in a Warning being issued to the Athlete unless exceptional circumstances apply.
3. The Ground Jury after consultation with the responsible medical officer may at any time exclude from further participation in a Competition or an entire Event any Athlete who is unfit to continue by reason of a serious or potentially serious injury, impairment, or health condition.
4. A Certified First Aid person needs to be presented at the entire show.

Article 169: Protection of Horses.

In cases of illness or injury during an Event, the Ground Jury will decide, after consulting the Veterinary Delegate or Commission, whether the Horse may continue in that or subsequent Competitions.

Article 170: Abuse of Horses.

1. No person may abuse a Horse during an Event or at any other time. "Abuse" means an action or omission which causes or is likely to cause pain or unnecessary discomfort to a Horse, including, but not limited to:

- a. To whip or beat a Horse excessively.
- b. To subject a Horse to any kind of electric shock device.
- c. To use spurs excessively or persistently.
- d. To jab the Horse in the mouth with the bit or any other device.
- e. To compete using an exhausted, lame, or injured Horse.
- f. To "rap" a Horse.
- g. To abnormally sensitize or desensitize any part of a Horse.
- h. To leave a Horse without adequate food, drink, or exercise.

2. Any person witnessing an Abuse must report it in the form of a protest without delay. If an Abuse is witnessed during or in direct connection with an Event, it should be reported as a protest to an Official. If the Abuse is witnessed at any other time, it should be reported as a protest to the Secretary General for referral to BREEF Dressage Committee.

Article 171: Medication Control and Anti-Doping.

1. Medication Control and Anti-Doping provisions are stated in the Anti-Doping Rules for Human Athletes (ADRHA), in conjunction with The World Anti-Doping Code, and in the Equine Anti-Doping and Controlled Medication Regulations (EADCM Regulations).

2. The decision as to whether a Horse may compete in an Event when under treatment or medication with a Prohibited Substance is made by the President of the Ground Jury on the recommendation of the Veterinary Delegate or Commission according to the procedures set out in the Veterinary Regulations.

3. It is forbidden for any rider or horse to take part in any competition whilst under the influence of any drug, stimulant, sedative or any banned substance included on the FEI, IOC, or Bahrain Olympic Council's list of prohibited

substances. Appropriate tests may be taken at any time by a medical or veterinary practitioner authorized by either Bahrain Olympic Council, the FEI, the IOC, or BREEF.

4. Infringement of this rule may incur the maximum penalty of disqualification and expulsion for life from NF.

5. Random Medication Control Program (MCP) will be conducted by FEI/NF, throughout the season. Refer to procedures as per the current FEI Dressage Rule Article 444 – refer to current FEI General Rules, the FEI Veterinary Regulations, the Equine Anti-Doping and Controlled Medication Regulations and any other applicable FEI Rules and Regulations.

Article 172: Veterinary Examination.

1. Horses attending a show and/or entered for competitions may be required by the Official Representative of NF, BREEF Veterinary Surgeon and/or the Senior Judge (for National Events) or the President of the Ground Jury (for International Events) to undergo a veterinary examination (including blood/urine sampling and/or swabbing) before being allowed to compete or subsequent to competition.

2. Examination of Boots/Bandages/Saddlery etc. used in the Warm-up area may be conducted prior to competition at the discretion of the Official Representative of NF, NF Veterinary Surgeon and/or the Senior Judge (for National Events) and/or the President of the Ground Jury (for International Events). The decision made by acting Officials following such an examination will be final and binding.

CHAPTER XIV: JUDGES AND OFFICIALS

Article 173: Mission.

1. The Mission of all Federation Officials is to promote, guide, develop and manage Equestrianism throughout The Kingdom of Bahrain in the aspects delegated to them, from time to time, by the NF.

2. The principal obligations include:

- a. To act with integrity in all matters.
- b. To represent NF effectively, loyally, diligently, and impartially.
- c. Common mission.
- d. To monitor Equestrianism worldwide in order that they and NF remain up to date with international developments.

Article 174: Conflict of Interest.

1. A substantial appearance of a conflict of interest exists whenever an individual involved in any capacity with the NF is involved in or perceived to be involved in multiple interests, one of which could possibly corrupt, or is perceived to corrupt, the motivation for an act in the other.
2. A conflict of interest is defined as any personal, professional or financial relationship, including relationships of family members that could influence or be perceived to influence objectivity when representing or conducting business or other dealings for or on behalf of the NF.
3. Conflicts must be avoided whenever practicable. However, conflicts may be linked to experience and expertise that is necessary to qualify Officials. The specific balance between conflict and expertise shall be regulated by the relevant Sport Rules.

Article 175: Reports.

1. Officials (Senior Judge and Chief Steward) are required to send Reports to BREEF at the conclusion of Events, in accordance with these Rules. Matters giving rise to Protests must be included in such reports. Reports must be submitted within 7 business days.
2. Failure to return Report(s) to the NF shall be sanctioned by the NF, first with a warning and then by a Suspension until the outstanding Report(s) has been provided to the NF.

Article 176: Federation Officials Code of Conduct A.

1. Be fully conversant with all the Rules and Regulations relative to their assigned duties.
2. Attend to their assigned duties on time and fully prepared.
3. Dress in the proper way or formally, as appropriate for weather conditions.

Article 177: Federation Officials Code of Conduct B.

1. Be absent or late for duty without permission.
2. Conduct himself in a manner which might bring the Country, the Sport or NF into disrepute.

Article 178: Judges.

1. Judges and Officials will always be subject to their Code of Practice, together with all the Rules, Regulations and Instructions of NF.
2. Judging will be conducted through the medium of English.
3. Bahrain Royal Equestrian and Endurance Federation shall appoint a panel of persons to act as Judges for Dressage Competitions from a list recommended by NF. Judges shall be appointed at the sole discretion of NF upon recommendation and with such qualifications as the Federation shall in each case require.
4. BREEF shall publish each year a list of the persons authorized.
5. BREEF may, from time to time, recommend to FEI, persons deemed suitable (by BREEF) to undertake technical courses for the qualification of Judges, Stewards and Veterinary Surgeons in the various categories as decided by the FEI. Such FEI qualifications for such personnel are always subject to annual review and endorsement or otherwise, by both FEI and NF.
6. Both NF and FEI (either collectively or separately) reserve the right to remove or demote any person from any list that should be deemed correct. Removal or demotion from the list will be supported by a full explanation. Actions which could contribute to the removal/demotion will be clearly communicated.
7. Permission from NF will be required if there is a clear conflict of interest between the local duties of the official and the said International Event. Any persons on the NF list, should notify the NF of their participation in such events.

Article 179: Official Representative at an Event.

1. The Official NF Representative will be the Senior Official at all Events.
2. The Ground Jury should consist of the dressage judges at the event, the most senior dressage judge will also be President of the Ground Jury.

Article 180: Senior Judge/Ground Jury – Duties.

1. Senior Judge (SJ)/Ground Jury (GJ) shall instruct the Organiser, as appropriate, to make any alterations to matters which come under his jurisdiction, which he considers necessary.
2. If there is no Technical Delegate, the President of the Ground Jury or the Senior Judge retains direct responsibility.
3. The SJ/GJ shall be competent to deal with all Protests within the meaning of this Rules relate to matters anything occurring during or in direct connection

with an Event and that they are presented within the period of its jurisdiction within the meaning of this Rules.

4. The period of jurisdiction of the SJ/GJ commences one (1) hour before the beginning of the first Horse inspection and terminates half an hour after the announcement of the final results in the relevant Event.

5. In appropriate cases involving veterinary matters during Events for which there is no and in the absence of an Appeal Committee, the President of the Veterinary Commission or the Veterinary Delegate at an Event must be/are invited to join the Ground Jury in an advisory capacity.

6. The SJ/GJ may impose the following penalties and sanctions on Officials, Owners of Horses, Persons Responsible, Athletes and team officials:

a. An oral Warning

b. A written warning

c. Elimination and/or Disqualification of an Athlete(s) and/or one (1) or more Horse(s) from Competition(s) and/or from an Event

d. In serious cases, immediate Disqualification during the Event with a referral to the Appeal Committee (or to the NF if there is no Appeal Committee).

7. Decisions must be made in writing to the parties concerned. Cases involving penalties must be recorded by the SJ/GJ.

8. There is no Appeal against Decisions of the SJ/GJ which are final and binding in the following cases:

a. Where the question for Decision is based on a factual observation of performance during a Competition or the awarding of marks for performance; Examples of issues that are finally decided by the SJ/GJ (which are not exhaustive): The Judges marks, whether a Horse was disobedient, whether the particular track followed by an Athlete has caused him to incur a penalty.

b. The Elimination or Disqualification of a Horse for veterinary reasons, including non-acceptance of a Horse at a Horse Inspection.

c. The Elimination or Disqualification of an Athlete for medical reasons.

d. The imposition of a Warning without additional penalties.

e. Immediate Elimination and/or disqualification in an Event.

9. The Ground Jury shall refer the following to the Appeal Committee/NF:

a. Any case matter which is beyond its competence.

b. Any case matter, within its competence which it considers deserving of more severe penalties than the SJ/GJ may impose under Article 164.4.

c. Any matter concerning alleged acts of abuse of Horses that does not require immediate action, the Decision of which is not immediately

required for the purpose of judging a Competition and which, having regard to its primary duty to judge the Competition, it deems more appropriate to be dealt with by the Appeal Committee/NF

Article 181: Stewards.

1. NF may appoint a Chief Steward for an event, who will act subject to the President of the Ground Jury (National Championships or International Events) or Senior Judge (National Competitions) and as such will be in charge of the collecting ring, exercise arena, stabling area and other locations thought necessary and who will report any transgressions of NF Rules to the President of the Ground Jury or Senior Judge.
2. OCs of all National Events must appoint a Chief Steward and an appropriate number of Stewards under the authority of the Chief Steward, wearing distinctive identification such as badges, arm bands, bibs, etc., with complete freedom of access to all areas mentioned in Article 183.5 below.
3. OCs are responsible for all administrative matters relating to the Appointment of the Chief Steward and the Stewards, unless Steward is appointed by NF.
4. During the whole Event in every part of the stables, in exercise and schooling areas, collecting rings and all other areas under control of the OC. The Chief Steward and the Stewards officiating with him/her at the Event shall:
 - a. Assists the Athletes in conducting reasonable training.
 - b. Intervenes in time to prevent any abuse of Horse by Athletes, grooms, owners or any other person.
 - c. Intervenes to prevent any contravention of this Rules or of the common principles of behavior, fairness and accepted standards of sportsmanship.
 - d. Be familiar with and assist with doping and medication control procedures.
5. One Steward must be on duty at the collecting ring whenever it is in use.
6. Any irregularities must be reported immediately by the Chief Steward to the SJ/President of the Ground Jury.
7. The Chief Steward is required to send a report to the Secretary General on the stewarding of the Event as a whole and on any incident which occurs during that Event. A copy of the report must be given to the SJ/GJ, to NF and to the OC of the Event.
8. The Chief Steward must be a person experienced in equestrian sports, particularly in the Discipline of the Event where he is appointed to officiate.
9. NF maintains a list of all qualified Stewards. The Chief Stewards must be selected from this list.

CHAPTER XV: THE LEGAL SYSTEM

Article 182: Preamble.

The Legal System provides for the following:

- The legal powers and responsibilities of BREEF, Officials, and bodies appointed under these Rules.
- A scale of penalties.
- A procedure for lodging protests and reports against the actions or behavior of individuals or bodies under the jurisdiction of NF.
- A process of appeal to a higher body against Decisions taken or penalties imposed by any person or body acting under these Rules.
- Before reaching a Decision on any protest or Appeal, the relevant body must examine the available evidence, whether written or oral, hear all the parties concerned (provided they are available) and consider all relevant material, in every case trying to reach a fair and equitable Decision.

Article 183: Federation Powers.

1. NF shall be empowered to direct the Organisers to refuse any entry with stating reasons; it shall be the sole judge of the qualification of any horse or rider to compete in any class/event and may, at its discretion, refuse the entry or transfer the entry of any such horse or rider to a lower or higher-ranking class.

2. NF may, from time to time and its sole discretion, have the power to delegate such duties, responsibilities and authority as it deems fit, to any individual committee or sub-committee and thus authorize such groups to act with authority on its behalf.

Article 184: Penalties and Warnings.

1. In deciding on the appropriate penalties to be imposed, the following factors shall be taken into consideration, together with any other relevant factors:

- a. Whether the action or omission resulted in an unfair advantage to the offender or an Athlete.
- b. Whether the action or omission resulted in a material disadvantage to any other person or body involved.

- c. Whether the action or omission involved the maltreatment of Horse(s).
 - d. Whether the action or omission affected the dignity or integrity of any person involved in the sport.
 - e. Whether the action or omission involved fraud, violence or abuse or similar criminal acts.
 - f. Whether the action or omission was deemed to be deliberate.
2. An oral or written warning is appropriate in cases of minor violations or contraventions committed unintentionally and without significant consequences.
3. Disqualification is appropriate when it is specified in the Rules, or if the circumstances require immediate action.
- a. Disqualification from a Competition means that the Athlete and Horse or Horses concerned - even should they change ownership - are removed from the list of starters and the classification and includes the forfeiture of prize money won in that particular Competition.
 - b. Disqualification from an Event means that the Athlete and Horse(s) concerned - even should they change ownership - may take no further part in that Event and it may include the forfeiture of any prize money won in previous Competitions at that Event where this is provided for in this Rules.
4. A Provisional or Final Suspension, on such terms and subject to conditions as NF, may impose, is appropriate in cases of intentional or very negligent violations or contravention. In certain cases, a Provisional or Final Suspension may be automatic under Rules:
- a. Suspension must be for a stated period and during that period the person, Horse or body suspended may take no part in Competitions or Events as an Athlete, Horse or Official or in the organization of, or participation in, any Event under the jurisdiction of the FEI or any Event under the jurisdiction of NF.
 - b. In deciding when any Suspension will commence, the appropriate body shall, in order to achieve a just penalty, have regard to the gravity of the offence.
 - c. Abuse of Horse(s) in any form (rapping, abnormal sensitization or desensitization of limbs, banned schooling methods etc.) shall entail a Suspension of a minimum of three (3) months up to life.
 - d. Incorrect behavior towards Event Officials or any other party connected with the Event (other Athlete, journalist, public etc.) shall entail a Suspension of a minimum of three (3) months up to twelve (12) months.
 - e. Fraud of any kind, violence and other acts defined as criminal by the national law prevailing at the Event shall entail a Suspension of a minimum of one (1) month up to life.

5. In cases of offences mentioned in paragraphs 4.c and 4.d above and which are of a less serious nature and/or in cases specified in the Sport Rules and/or as mentioned in

a. The SJ/President of the Ground Jury, the President of the Appeal Committee and the Chief Steward may deliver to the Person Responsible a Written Warning, either by hand or by any other suitable means.

b. Should the same Person Responsible receive one (1) more Written Warning at the same or any other International Event within one year of the delivery of the first Written Warning, the Person Responsible shall be automatically suspended for a period of two (2) months from the day following the Event at which the Person Responsible is competing after official notification from NF shall be responsible to notify the Person Responsible of such suspension.

6. The penalty imposed in any given case can consist of a combination of Suspensions and disqualification. The duration of a Suspension shall be decided according to the guidelines mentioned in Article 186.4 above and to the circumstances of the case.

a. Abuse of Horse(s) in any form (rapping, abnormal sensitization or desensitization of limbs, banned schooling methods etc.) shall entail a Suspension of a minimum of three (3) months up to life.

b. Incorrect behavior towards Event Officials or any other party connected with the Event (other Athlete, journalist, public etc.) shall entail a Suspension of a minimum of three (3) months up to twelve (12) months.

c. Fraud of any kind, violence and other acts defined as criminal by the national law prevailing at the Event shall entail a Suspension of a minimum of one (1) month up to life.

7. In cases of offences mentioned in paragraphs 4.c and 4.d above and which are of a less serious nature and/or in cases specified in the Sport Rules and/or as mentioned in Article 186:

a. The SJ/President of the Ground Jury, the President of the Appeal Committee and the Chief Steward may deliver to the Person Responsible a Written Warning, either by hand or by any other suitable means.

b. Should the same Person Responsible receive one (1) more Written Warning at the same or any other International Event within one year of the delivery of the first Written Warning, the Person Responsible shall be automatically suspended for a period of two (2) months from the day following the Event at which the Person Responsible is competing after official notification from NF shall be responsible to notify the Person Responsible of such suspension.

8. The penalty imposed in any given case can consist of a combination of Suspensions and disqualification. The duration of a Suspension shall be decided

according to the guidelines mentioned in Article 186.4 above and to the circumstances of the case.

CHAPTER XVI: OBJECTIONS

Article 185: Submission of Objections.

1. For an objection to be valid it must be in writing, addressed to the President of the Ground Jury for FEI International Competitions or the Senior Judge for National Competitions. Refer to current FEI General Rules for a full explanation for FEI International Dressage Competitions.
2. The objection should be lodged with the President of the Ground Jury. The written objection should include the fullest details, including the Article Number/s allegedly offended. Written/signed/dated reports from witnesses and dated photographs and/or videos may be included.
3. An objection does not include a query made to the FEI Ground Jury at International Competitions or Senior Judge at National Competitions or other official of the event, before the commencement of a competition.
4. An objection may only be made by:
 - a. An adult owner or registered Rider, who is involved in the competition, or their respective duly authorized agent, or the duly authorized guardian of a minor, competing in the competition.
 - b. The Chef d'Equipe.
 - c. NF Representative or an Official of the event.

Article 186: Time Limit.

1. The objection must be lodged within the following time limits:
 - a. Concerning the eligibility of any rider or horse not less than 30mins before the commencement of the class.
 - b. Concerning the arena, plan or anything related to the way the competition is being conducted not less than 30 minutes before the commencement of the competition.
 - c. Concerning any incident or decision arising during the competition not later than 30 minutes after the announcement of the results.

Article 187: Referral to Federation.

The foregoing shall not prevent any matter being drawn to the attention of NF for any actions NF may deem appropriate. However, reports lodged with the Secretary General 10 days after the event will not be considered.

Article 188: Query.

Any rider, or agent, who has a query, rather than an objection, at any time during the show, must, for it to be valid, make it in writing, address it to the President of the Ground Jury and lodge it with NF Steward.

Article 189: Appeal.

1. An appeal may be made against the Senior Judge at National Competitions on an objection lodged.
2. For such an appeal to be legal it must be made in writing, lodged with the BREEF Dressage Committee within one (1) hour of the previous decision of the Senior Judge at National competitions.
3. If an appeal is lodged, The BREEF Dressage Committee may deal with the matter directly, or if they deem it necessary, call upon two suitable persons to form an Appeal Committee. The decision of the Appeal Committee is final.

Appendix 1: Permitted Bridles/Bits.

Saddles

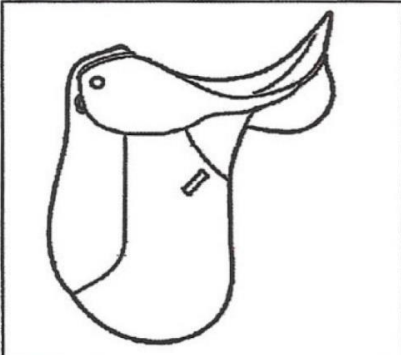

Example of Dressage saddle

Bridles

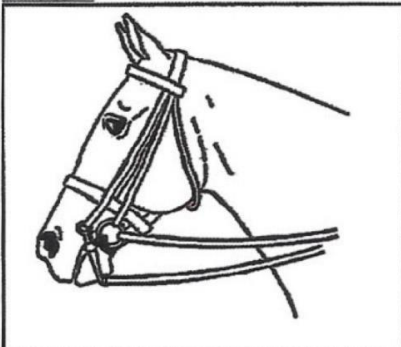

Ex. of Double Bridle, used with cavesson noseband, throat lash, bridoon and curb bits, and curb chain

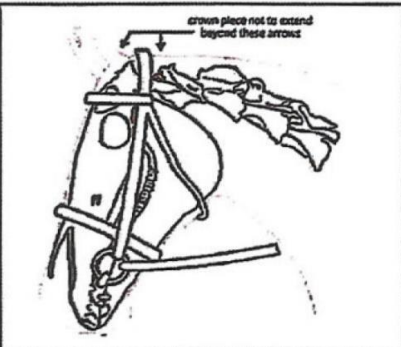

Crown piece may not extend beyond the two arrows

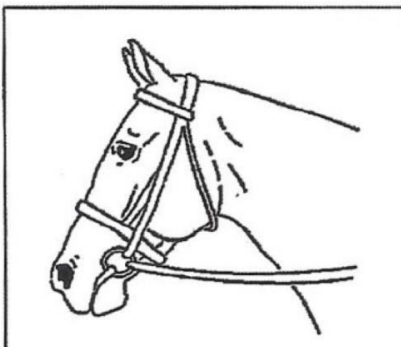

Ex. of Cavesson noseband

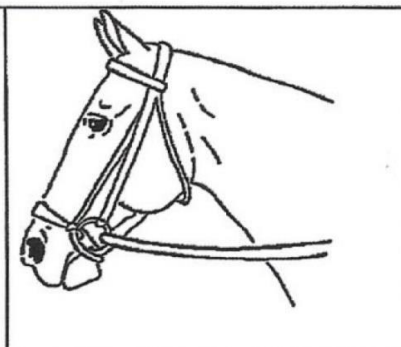

Ex. of dropped noseband

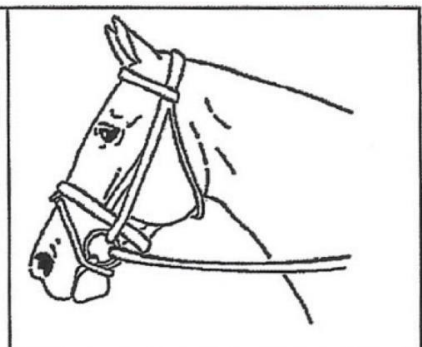

Ex. of flash strap

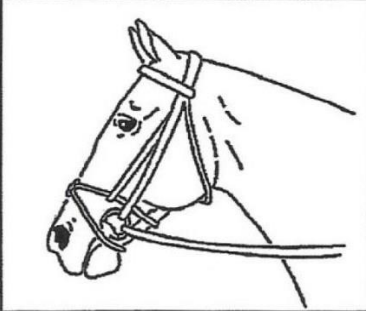
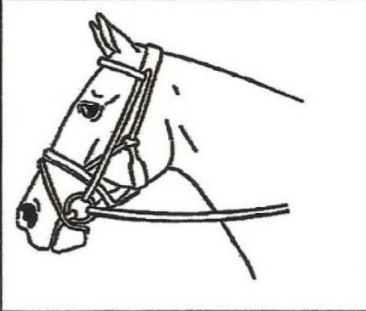
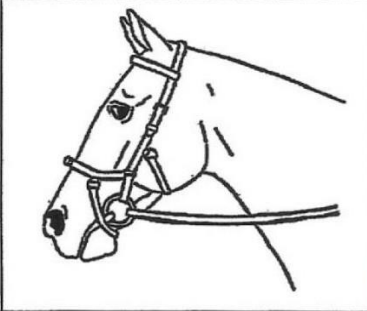
		
Ex. of crossed/mexican/grackle noseband	Ex. of combined noseband – no throat lash necessary	Ex. of Micklem style bridle – no throatlash necessary



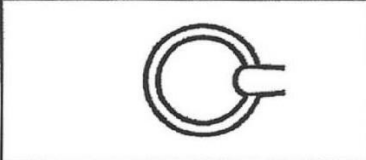
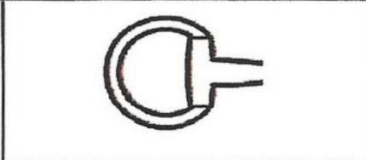
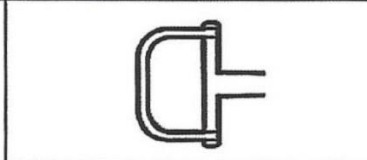
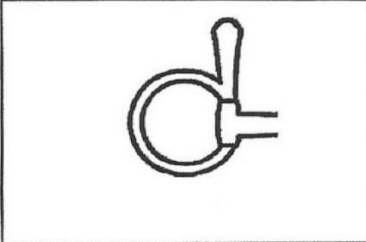
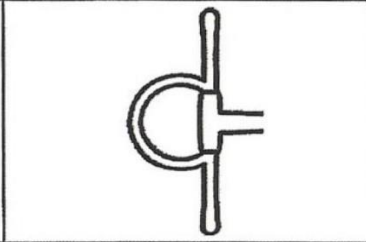
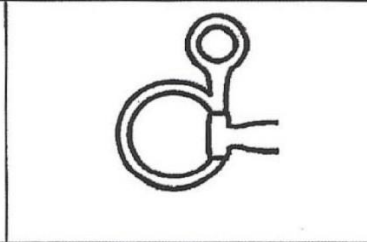
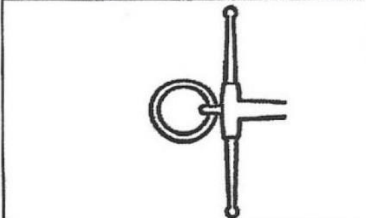

Bits

Cheek Pieces:

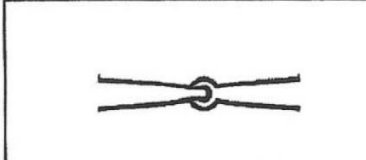
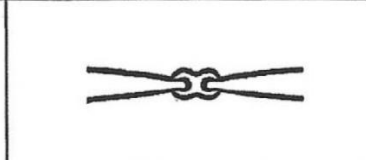
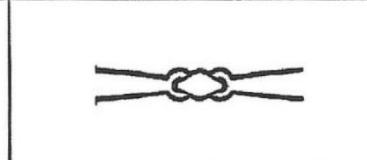
		
Ex. of Loose Ring cheek	Ex. of Eggbutt cheek	Ex. of D-Ring cheek
		
Ex. of upper cheek	Ex. of full cheek	Ex. of hanging cheek
		
Ex. of Fulmer cheek		

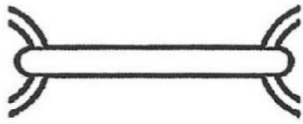
Mouthpieces:



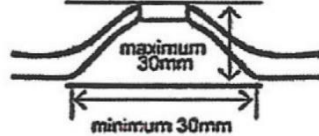

		
Ex. of single jointed mouthpiece	Ex. of double jointed mouthpiece	Ex. of double jointed mouthpiece

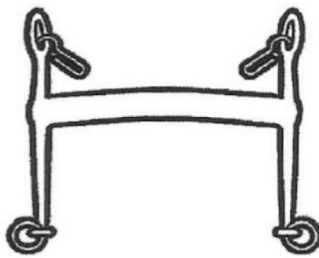
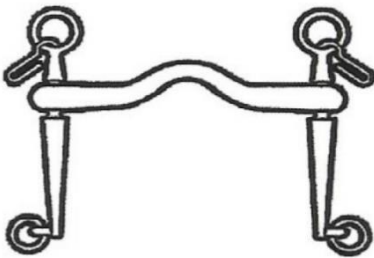
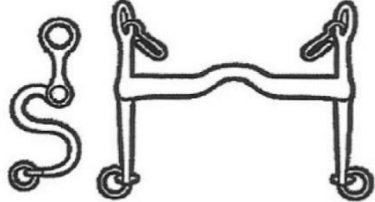
		
Ex. of unjointed mouthpiece	Ex. of barrel joint	Ex. of ball joint
		
Ex. of double ball joint	Ex. of centrepiece with a roller	Port deviation measurements

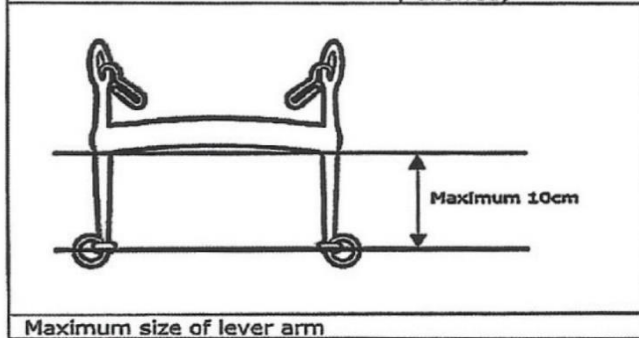
Curb Bits:

		
Ex. of curb with straight cheeks	Ex. of curb with port and sliding mouthpiece (rotating arms also allowed)	Ex. of curb with S cheeks



	
Ex. of Curb chain	Ex. of Leather cover for curb chain
	
Ex. of lip strap	Ex. of cover for curb chain

Appendix 2: Arenas.
20 x 40-meter Arena

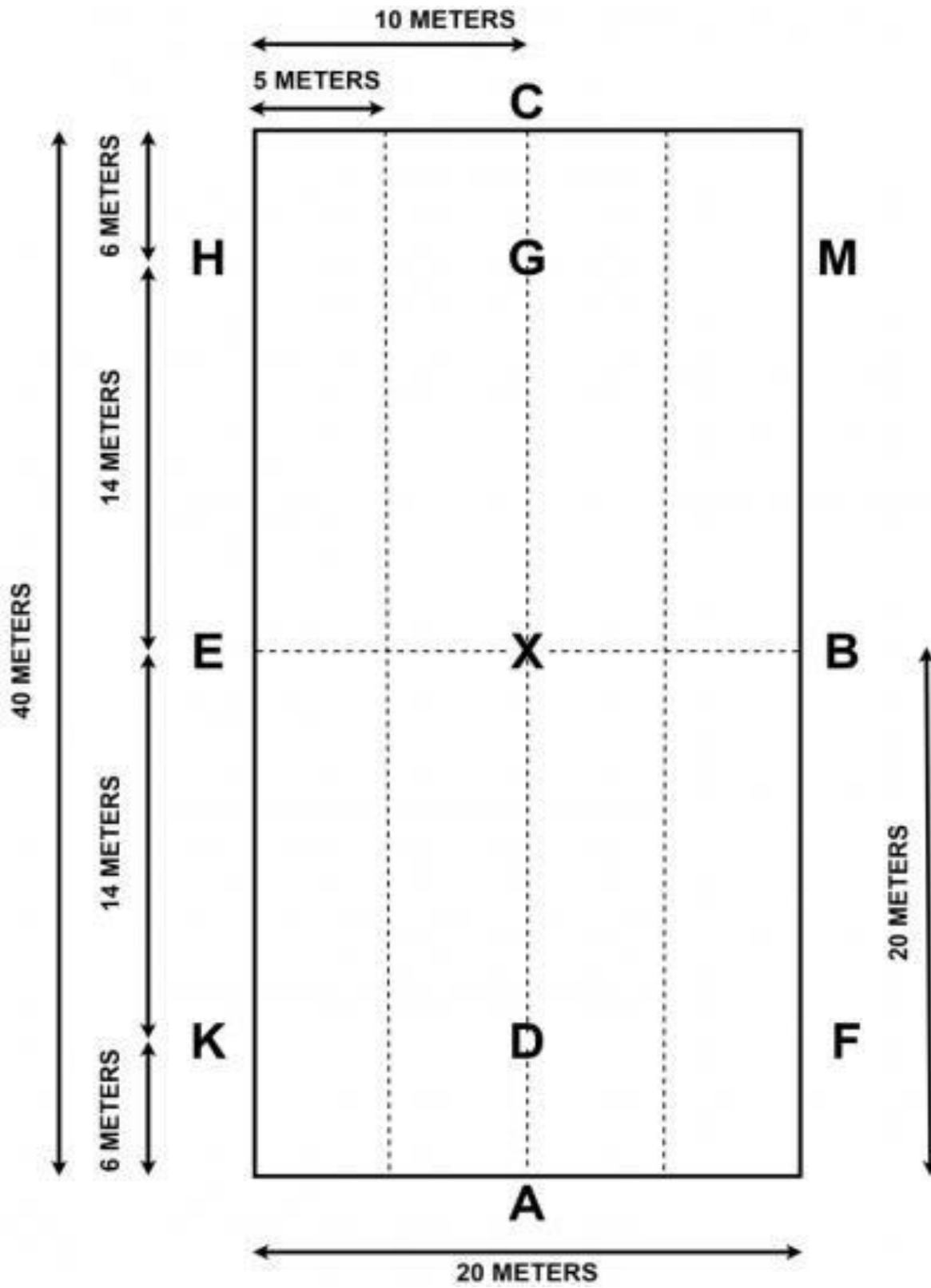

20 x 60-meter Arena

